

Model BL and Model BL-A

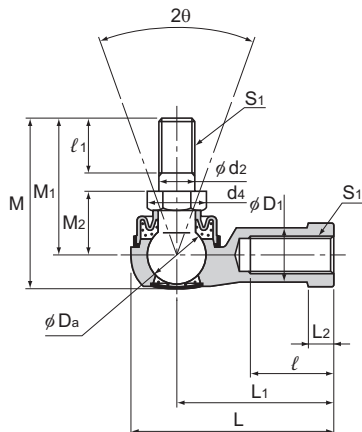

Model No.	Outer dimensions			Threaded S ₁ JIS Class 2	Holder dimensions					
	Length L	Diameter D	Height M		L ₁	ℓ	L ₂	D ₁	D ₂	W 0 -0.3
BL 4DA	24.5	13	20	M4×0.7	18	8	4	7.5	9.5	8
BL 5DA	34.5	15	26.7	M5×0.8	27	15	4	9	12	10
BL 6D	38	16	32.6	M6×1	30	16	5	10	13	11
BL 8D	45.5	19	38.6	M8×1.25	36	19	6	12.5	16	14
BL 10D	55.5	25	46.3	M10×1.25	43	23	7	14.5	19	17
BL 10BD	55.5	25	52.3	M10×1.5	43	23	7	14.5	19	17
BL 12D	64.5	29	52.7	M12×1.25	50	26	8	17.5	22	19
BL 12BD	64.5	29	59.7	M12×1.75	50	26	8	17.5	22	19
BL 14D	74	34	68.4	M14×1.5	57	30	10	20	25	22
BL 14BD	74	34	74.4	M14×2	57	30	10	20	25	22
BL 16D	83	38	74	M16×1.5	64	34	11	22	27	24
BL 16BD	83	38	80	M16×2	64	34	11	22	27	24

Note) Model BL-A is only available in size 4 and 5.

[Material]

Holder : A-1 alloy (BL4 to 5) (see **A22-5**)
 : High strength zinc alloy (BL6 to 16) (see **A22-6**)
 Ball shank : Lightly Carburized Carbon Steel Ball:
 650 HV or higher
 Shank S35C (20 to 28 HRC)
 Chromate treatment
 Boot : NBR special synthetic rubber

[Spherical Clearance]

Radial direction : 0.02 to 0.06mm
 Axial direction : 0.3mm or less

[Tolerance of the Mating Hole of the Ball Shank]

H10 is recommended

Model number coding

BL6 D L

Model number | D | L
 With boot attached | | Screw symbol

Screw symbol	No symbol	L
Holder unit set screw	Right-hand	Left-hand
Ball shank	Right-hand	

Note) No model is available without boot.

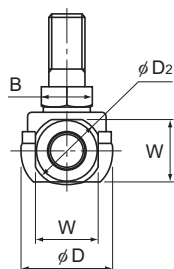

Unit: mm

Ball shank dimensions							Ball diameter Da	Permissible tilt angles 20°	Applied static load C _s N	Yield-point strength P _k N	Mass g
d ₂ h9	M ₁	M ₂ ±0.3	ℓ ₁	Hexagon B 0 -0.3	d ₄						
4	15	7	6	7	8.1	7.938	40	4510	1370	7	
5	21	10	8	8	9.2	9.525	40	6470	2250	12	
6	26	11	11	10	11.6	11.112	40	9900	3920	26	
8	31	14	12	12	13.8	12.7	40	12500	6570	49	
10	37	17	15	14	16.2	15.875	40	18300	11300	87	
10	43	17	21	14	16.2	15.875	40	18300	11300	90	
12	42	19	17	17	19.6	19.05	40	26700	16400	143	
12	49	19	24	17	19.6	19.05	40	26700	16400	148	
14	56	21.5	22	19	21.9	22.225	40	36400	19800	235	
14	62	21.5	28	19	21.9	22.225	40	36400	19800	245	
16	60	23.5	23	22	25.4	22.225	30	36400	26900	315	
16	66	23.5	29	22	25.4	22.225	30	36400	26900	325	

[Yield-Point Strength]

It indicates the strength in the direction shown in the figure below.

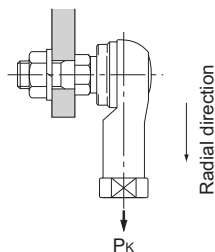
**[Lubrication]**

Lithium soap group grease No. 2 is contained in the boot and the cap.

[Identification of Left-hand Thread]

If the female threading is left-handed, its identification depends on the marking.

Threaded	Identification
	Cap marking
Right-hand	—
Left-hand	L mark