

LH Series Ball Slide Dimension Table

Flange Type

LAH-EM/EMZ
(formerly EL-ELZ-90)
LAH-GM/GMZ
(formerly GL-GLZ-90)

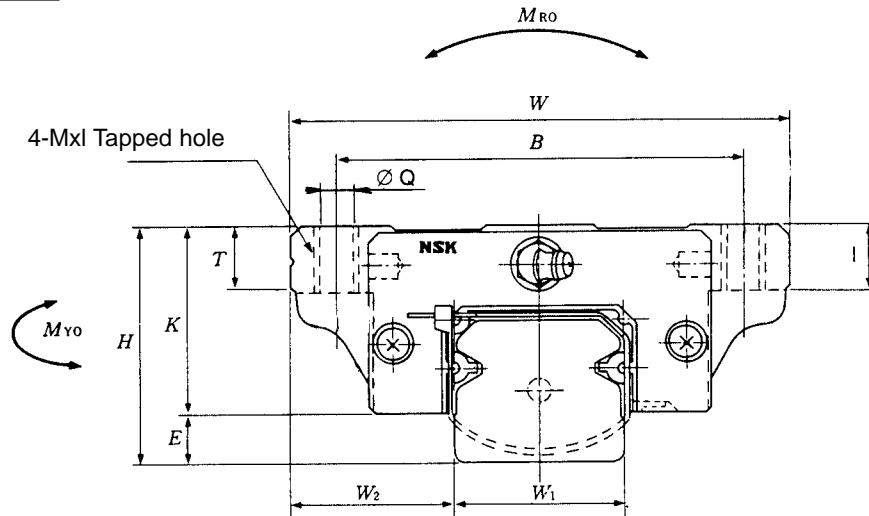

Model No.	Ass'y Dimensions			Ball Slide Dimensions									
	H	E	W ₂	W	B X J	L	L ₁	J ₁	K	T	M x l	Ø Q x l	Bolt Size Thru Hole Q
LAH15 EM/EMZ GM/GMZ	24	4.6	16	47	38 x 30	55 74	39 58	4.5 14	19.4	8	M5 x 8	Ø4.4 x 8	M4
LAH20 EM/EMZ GM/GMZ	30	5	21.5	63	53 x 40	69.8 91.8	50 72	5 16	25	10	M6 x 10	Ø5.3 x 10	M5
LAH25 EM/EMZ GM/GMZ	36	7	23.5	70	57 x 45	79 107	58 86	6.5 20.5	29	11	M8 x 10	Ø6.8 x 10	M6
LAH30 EM/EMZ GM/GMZ	42	9	31	90	72 x 52	98.6 124.6	72 98	10 23	33	11	M10 x 12	Ø8.6 x 12	M8
LAH35 EM/EMZ GM/GMZ	48	9.5	33	100	82 x 62	109 143	80 114	9 26	38.5	12	M10 x 13	Ø8.6 x 13	M8
LAH45 EM/EMZ GM/GMZ	60	14	37.5	120	100 x 80	139 171	105 137	12.5 28.5	46	13	M12 x 15	Ø10.5 x 15	M10
LAH55 EM/EMZ GM/GMZ	70	15	43.5	140	116 x 95	163 201	126 164	15.5 34.5	55	15	M14 x 18	Ø12.5 x 18	M12
LAH65 EM/EMZ GM/GMZ	90	16	53.5	170	142 x 110	193 253	147 207	18.5 48.5	74	23	M16 x 24	Ø14.6 x 24	M14

Note : W₁ rail dimensions are on Page 12.

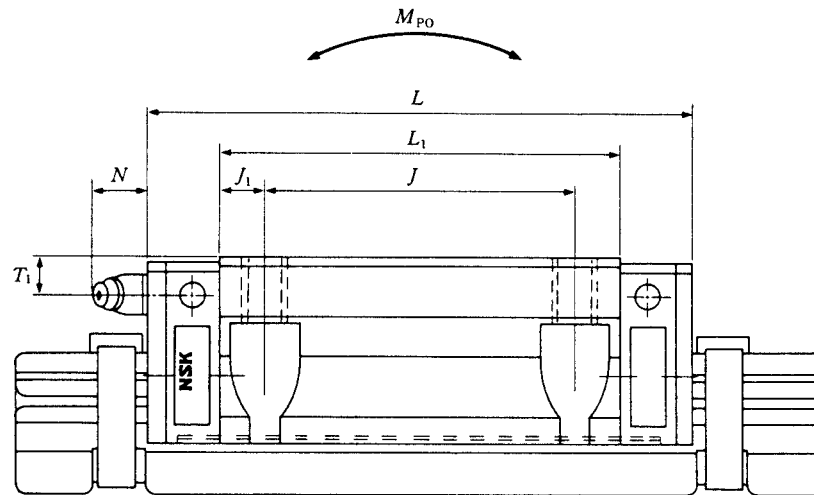

Unit : mm

Grease Fitting			Basic Load Ratings					Weight (kgf)	Model No.
Mounting Hole Thread Spec.	T_1	N	Dynamic C (kgf)	Static C_0 (kgf)	Static Moment (kgf·m)				
					M_{RO}	M_{PO}	M_{YO}		
Ø3 (thru hole)	4.5	3.3	850	1650	10	8	8	0.17	LAH15 EM/EMZ GM/GMZ
			1140	2550	15	18	18		
M6x0.75	5	11	1450	2560	22	18	18	0.45	LAH20 EM/EMZ GM/GMZ
			1860	4020	31	35	35		
M6x0.75	6	11	2140	4000	36	32	31	0.63	LAH25 EM/EMZ GM/GMZ
			2740	5340	48	54	53		
M6x0.75	7	11	2980	5490	60	50	49	1.2	LAH30 EM/EMZ GM/GMZ
			3800	7310	80	86	85		
M6x0.75	8	11.5	3960	7010	96	75	73	1.7	LAH35 EM/EMZ GM/GMZ
			5060	9930	136	144	141		
PT1/8	10	13	6740	12100	216	170	168	3	LAH45 EM/EMZ GM/GMZ
			8130	14900	264	251	248		
PT1/8	11	13	9940	17100	367	293	288	5	LAH55 EM/EMZ GM/GMZ
			12000	21100	449	435	426		
PT1/8	19	13	15100	24500	629	495	484	10	LAH65 EM/EMZ GM/GMZ
			19300	32700	834	850	830		