

Rexroth Ball Rail Systems

Standard Runner Blocks, Steel Version

Runner Block 1651-

Standard Width

With ball chain as an option

Versions:

- Runner block without ball chain: for part numbers, see table
- Runner block with ball chain: part numbers 1651-...-22

Dynamic characteristics

Speed $v_{\max} = 5 \text{ m/s}$

Acceleration $a_{\max} = 500 \text{ m/s}^2$

Other technical data, see chapter "General Technical Data and Calculations".

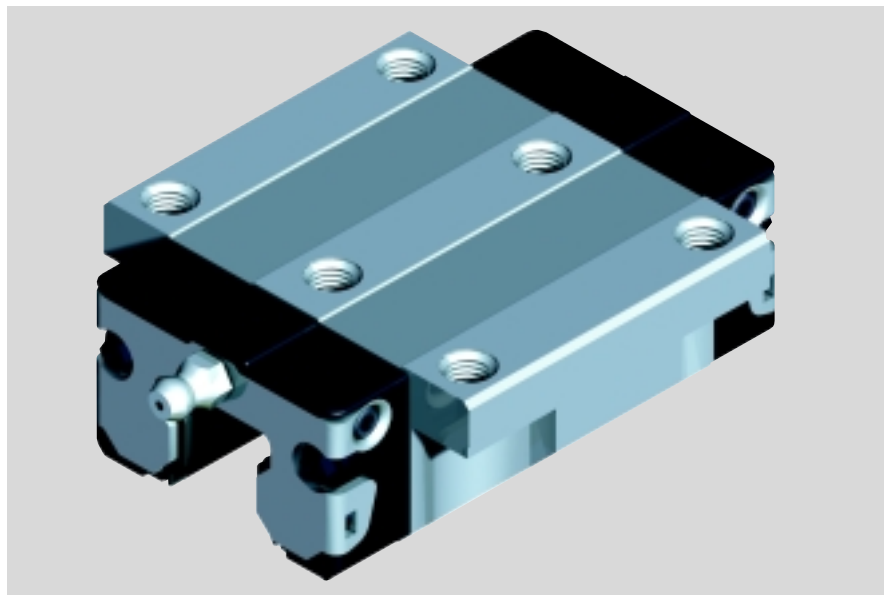

Part numbers

Size	Accuracy class	Part numbers for runner blocks for preload class			
		up to approx. 10 μm clearance	Preload 0.02 C	Preload 0.08 C	Preload 0.13 C
15	UP		1651-119-20	1651-129-20	1651-139-20
	SP		1651-111-20	1651-121-20	1651-131-20
	P		1651-112-20	1651-122-20	1651-132-20
	H	1651-193-20	1651-113-20	1651-123-20	
	N	1651-194-20	1651-114-20	1651-124-20	
20	UP		1651-819-20	1651-829-20	1651-839-20
	SP		1651-811-20	1651-821-20	1651-831-20
	P		1651-812-20	1651-822-20	1651-832-20
	H	1651-893-20	1651-813-20	1651-823-20	
	N	1651-894-20	1651-814-20	1651-824-20	
25	UP		1651-219-20	1651-229-20	1651-239-20
	SP		1651-211-20	1651-221-20	1651-231-20
	P		1651-212-20	1651-222-20	1651-232-20
	H	1651-293-20	1651-213-20	1651-223-20	
	N	1651-294-20	1651-214-20	1651-224-20	
30	UP		1651-719-20	1651-729-20	1651-739-20
	SP		1651-711-20	1651-721-20	1651-731-20
	P		1651-712-20	1651-722-20	1651-732-20
	H	1651-793-20	1651-713-20	1651-723-20	
	N	1651-794-20	1651-714-20	1651-724-20	
35	UP		1651-319-20	1651-329-20	1651-339-20
	SP		1651-311-20	1651-321-20	1651-331-20
	P		1651-312-20	1651-322-20	1651-332-20
	H	1651-393-20	1651-313-20	1651-323-20	
	N	1651-394-20	1651-314-20	1651-324-20	
45*	UP		1651-419-20	1651-429-20	1651-439-20
	SP		1651-411-20	1651-421-20	1651-431-20
	P		1651-412-20	1651-422-20	1651-432-20
	H	1651-493-20	1651-413-20	1651-423-20	
	N	1651-494-20	1651-414-20	1651-424-20	

Note on dynamic load capacities and moments (see table)

Determination of dynamic load capacities and moments is based on a travel life of 100 000 m.

However, frequently this is determined on the basis of only 50 000 m.

In this case for comparison: multiply values C , M_t and M_L by 1.26 in accordance with Rexroth table.

* Under preparation

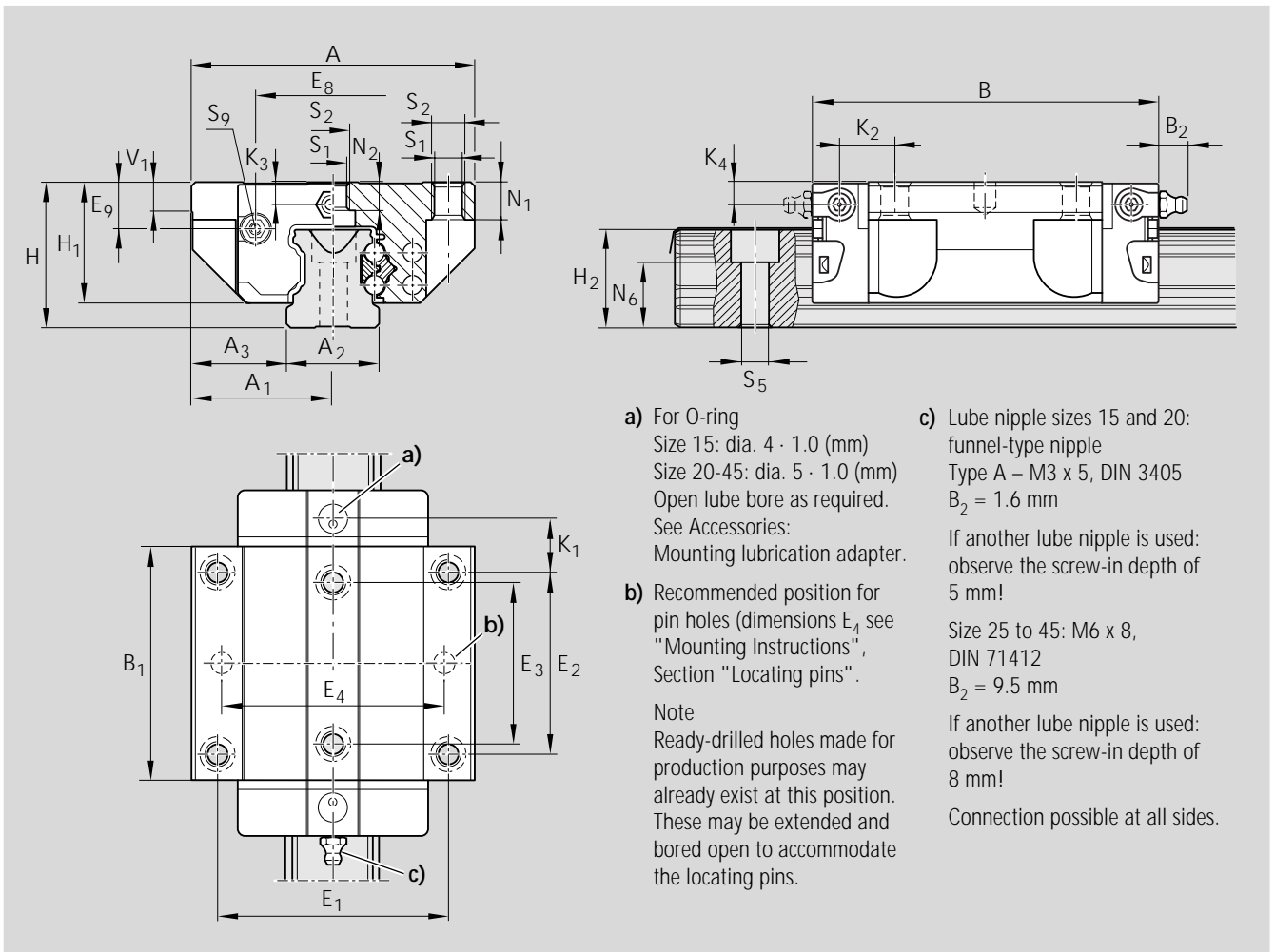

- a) For O-ring
 Size 15: dia. 4 · 1.0 (mm)
 Size 20-45: dia. 5 · 1.0 (mm)
 Open lube bore as required.
 See Accessories:
 Mounting lubrication adapter.
- b) Recommended position for pin holes (dimensions E_4 see "Mounting Instructions", Section "Locating pins").
 Note
 Ready-drilled holes made for production purposes may already exist at this position. These may be extended and bored open to accommodate the locating pins.
- c) Lube nipple sizes 15 and 20: funnel-type nipple
 Type A – M3 x 5, DIN 3405
 $B_2 = 1.6$ mm
 If another lube nipple is used: observe the screw-in depth of 5 mm!
 Size 25 to 45: M6 x 8, DIN 71412
 $B_2 = 9.5$ mm
 If another lube nipple is used: observe the screw-in depth of 8 mm!
 Connection possible at all sides.

Dimensions (mm)																				
Size	A	A ₁	A ₂	A ₃	B	B ₁	H	H ₁	H ₂ ¹⁾	H ₂ ²⁾	V ₁	E ₁	E ₂	E ₃	E ₈	E ₉	K ₁	K ₂	K ₃	K ₄
15	47	23.5	15	16.0	58.2	39.2	24	19.90	16.30	16.20	5.0	38	30	26	24.55	6.70	8.00	9.6	3.20	3.20
20	63	31.5	20	21.5	75.0	49.6	30	25.35	20.75	20.55	6.0	53	40	35	32.50	7.30	11.80	11.8	3.35	3.35
25	70	35.0	23	23.5	86.2	57.8	36	29.90	24.45	24.25	7.5	57	45	40	38.30	11.50	12.45	13.6	5.50	5.50
30	90	45.0	28	31.0	97.7	67.4	42	35.35	28.55	28.35	7.0	72	52	44	48.40	14.60	14.00	15.7	6.05	6.05
35	100	50.0	34	33.0	110.5	77.0	48	40.40	32.15	31.85	8.0	82	62	52	58.00	17.35	14.50	16.0	6.90	6.90
45	120	60.0	45	37.5	137.6	97.0	60	50.30	40.15	39.85	10.0	100	80	60	69.80	20.90	17.30	19.3	8.20	8.20

¹⁾ Dimension H₂ with rail seal cover strip

²⁾ Dimension H₂ without rail seal cover strip

Size	Dimensions (mm)								Mass (kg)	Load capacities (N) ³⁾		Moments (Nm)			
	N ₁	N ₂	N ₆ ^{±0.5}	S ₁	S ₂	S ₅	S ₉	C dyn.		C ₀ stat.	M _t dyn.	M _{t0} stat.	M _L dyn.	M _{L0} stat.	
15	5.2	4.4	10.3	4.3	M5	4.4	M2.5-3.5 deep	0.20	7 800	13 500	130	74	40	71	
20	7.7	5.2	13.2	5.3	M6	6.0	M3-5 deep	0.45	18 800	24 400	240	310	130	165	
25	9.3	7.0	15.2	6.7	M8	7.0	M3-5 deep	0.65	22 800	30 400	320	430	180	240	
30	11.0	7.9	17.0	8.5	M10	9.0	M3-5 deep	1.10	31 700	41 300	540	720	290	380	
35	12.0	10.2	20.5	8.5	M10	9.0	M3-5 deep	1.60	41 900	54 000	890	1160	440	565	
45	15.0	14.4	23.5	10.4	M12	14.0	M4-7 deep	3.00	68 100	85 700	1830	2310	890	1130	

³⁾ Load capacities for version without ball chain. Load capacities for version without ball chain, see Product Overview with load capacities.

Rexroth Ball Rail Systems

Standard Runner Blocks, Steel Version

Runner Block 1651-

Standard Width

Dynamic characteristics

Speed $v_{\max} = 3 \text{ m/s}$

Acceleration $a_{\max} = 250 \text{ m/s}^2$

Other technical data, see chapter "General Technical Data and Calculations".

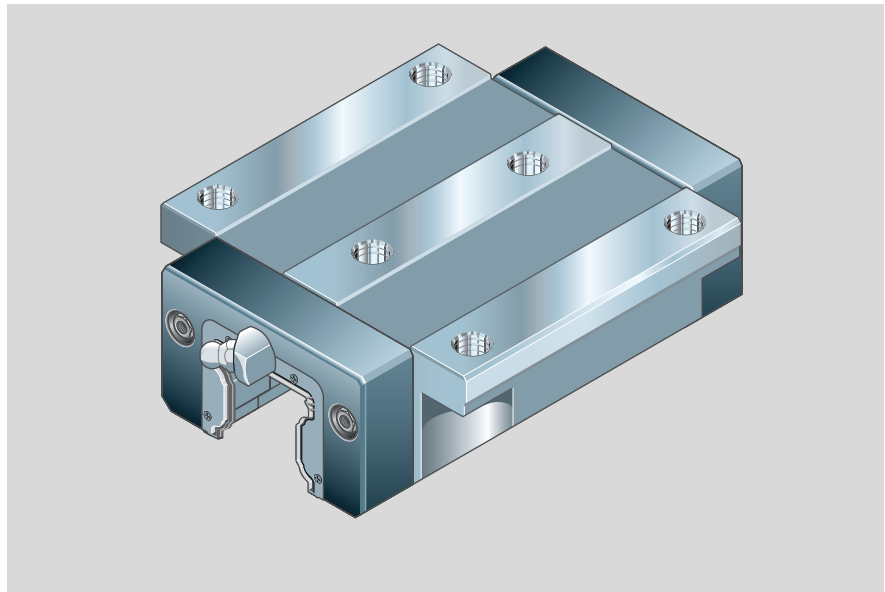

Part numbers

Size	Accuracy class	Part numbers for runner blocks for preload class			
		up to approx. 10 μm clearance	Preload 0.02 C	Preload 0.08 C	Preload 0.13 C
45*	UP		1651-419-10	1651-429-10	1651-439-10
	SP		1651-411-10	1651-421-10	1651-431-10
	P		1651-412-10	1651-422-10	1651-432-10
	H	1651-493-10	1651-413-10	1651-423-10	
	N	1651-494-10	1651-414-10	1651-424-10	
55	UP		1651-519-10	1651-529-10	1651-539-10
	SP		1651-511-10	1651-521-10	1651-531-10
	P		1651-512-10	1651-522-10	1651-532-10
	H	1651-593-10	1651-513-10	1651-523-10	
	N	1651-594-10	1651-514-10	1651-524-10	
65	UP		1651-619-10	1651-629-10	1651-639-10
	SP		1651-611-10	1651-621-10	1651-631-10
	P		1651-612-10	1651-622-10	1651-632-10
	H	1651-693-10	1651-613-10	1651-623-10	
	N	1651-694-10	1651-614-10	1651-624-10	

* Phased-out model

Note on dynamic load capacities and moments (see table)

Determination of dynamic load capacities and moments is based on a travel life of 100 000 m.

However, frequently this is determined on the basis of only 50 000 m.

In this case for comparison: multiply values **C**, **M_t** and **M_L** by 1.26 in accordance with Rexroth table.

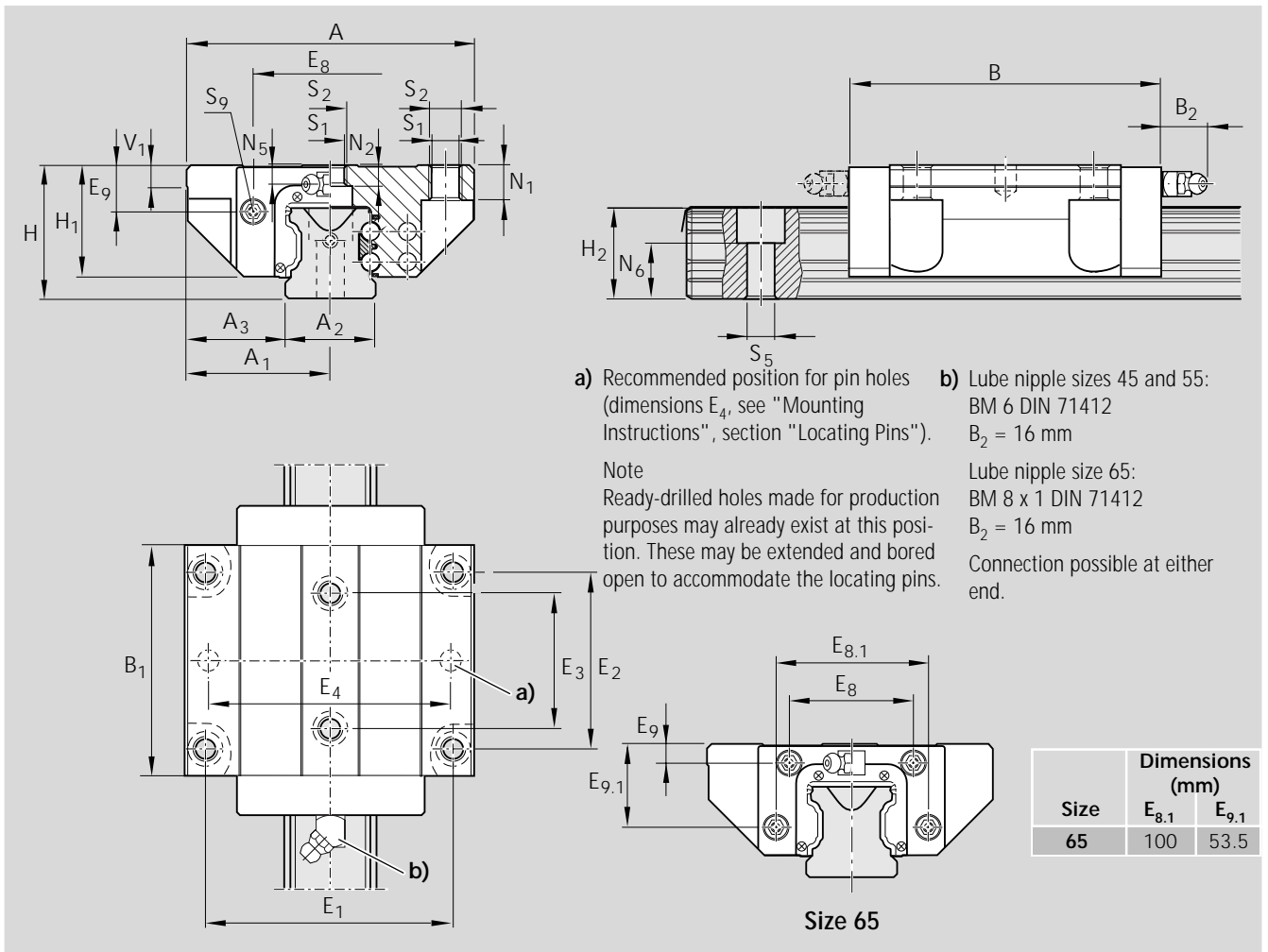

Size	Dimensions (mm)																	
	A	A_1	A_2	A_3	B	B_1	H	H_1	$H_2^{1)}$	$H_2^{2)}$	V_1	E_1	E_2	E_3	E_8	E_9	N_1	N_2
45*	120	60.0	45	37.5	133	97.0	60	50.0	40.15	39.85	10.0	100	80	60	69.8	20.9	15.0	12.4
55	140	70.0	53	43.5	159	115.5	70	57.0	48.15	47.85	12.0	116	95	70	80.0	22.3	18.0	13.5
65	170	85.0	63	53.5	188	139.6	90	76.0	60.15	59.85	15.0	142	110	82	76.0	11.0	23.0	14.0

¹⁾ Dimension H_2 with rail seal cover strip

²⁾ Dimension H_2 without rail seal cover strip

Size	Dimensions (mm)							Mass (kg)	Load capacities (N)		Moments (Nm)			
	N_5	$N_6^{±0.5}$	S_1	S_2	S_5	S_9	C dyn.		C_0 stat.	M_t dyn.	M_{t0} stat.	M_L dyn.	M_{L0} stat.	
45*	8.0	23.5	10.5	M12	14.0	M4-7 deep	2.90	68 100	85 700	1 830	2 310	890	1 130	
55	9.0	29.0	12.5	M14	16.0	M5-8 deep	5.20	98 200	121 400	3 100	3 860	1 540	1 905	
65	16.0	38.5	14.5	M16	18.0	M4-7 deep	10.25	123 000	192 700	4 850	7 610	2 430	3 815	