

Standard Runner Blocks, Steel version

Runner Block SNH

Runner block SNH R1821 ... 10 Slimline, normal, high

Further runner block versions

- with aluminum end caps
- for oil and grease lubrication from above
- for central oil lubrication systems
- for wall mounting

See the relevant sections for part numbers.

For corrosion-resistant runner blocks, Resist CR, matte silver hard chrome plated, see section on "Standard Runner Blocks, Resist CR."

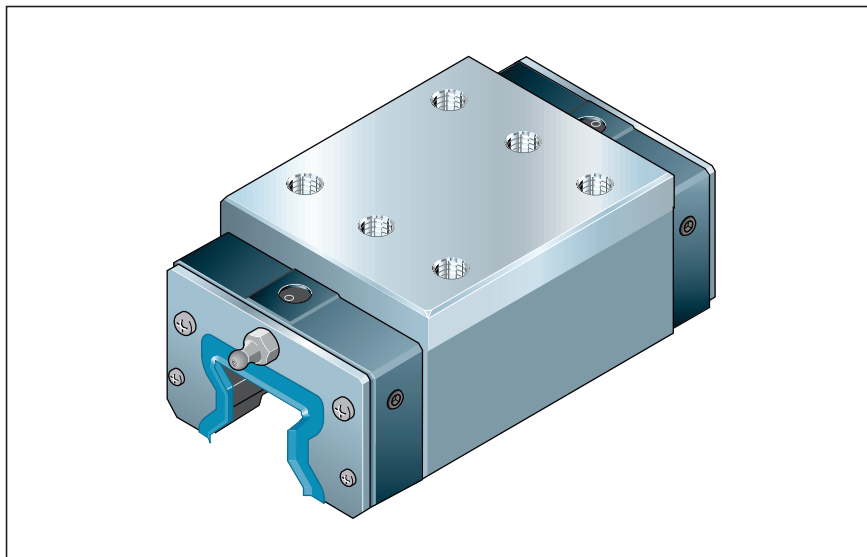

Recommended preload and accuracy class combinations

- For preload class C2: H and P
- For preload class C3: P and SP

Preference should be given to runner blocks with preload C2.

Runner blocks with preload C1 are available on request. Part number: R1821 .1. 10

Preload classes

C1 = preload 3% C
(on request)

C2 = preload 8% C

Size	Accuracy class	Part numbers for preload class	
		C2	C3
25	H	R1821 223 10	–
	P	R1821 222 10	R1821 232 10
	SP	R1821 221 10	R1821 231 10
	UP	R1821 229 10	R1821 239 10
35	H	R1821 323 10	–
	P	R1821 322 10	R1821 332 10
	SP	R1821 321 10	R1821 331 10
	UP	R1821 329 10	R1821 339 10
45	H	R1821 423 10	–
	P	R1821 422 10	R1821 432 10
	SP	R1821 421 10	R1821 431 10
	UP	R1821 429 10	R1821 439 10
55	H	R1821 523 10	–
	P	R1821 522 10	R1821 532 10
	SP	R1821 521 10	R1821 531 10
	UP	R1821 529 10	R1821 539 10

Note on dynamic load capacities and moments (see table)

The dynamic load capacities and moments are based on 100,000 m travel. However, a travel of just 50,000 m is often taken as a basis.

If this is the case, for comparison purposes: Multiply values **C**, **M_t** and **M_L** from the table by 1.23.

Size	Load capacities (N)		Moment loads (Nm)			
	C	C ₀	M _t	M _{t0}	M _L	M _{L0}
25	26 900	53 200	348	690	260	520
35	56 300	113 500	1 114	2 245	700	1 400
45	92 300	184 800	2 277	4 559	1 430	2 860
55	128 900	248 600	3 779	7 288	2 400	4 620

Standard runner block SNH R1821 ... 10

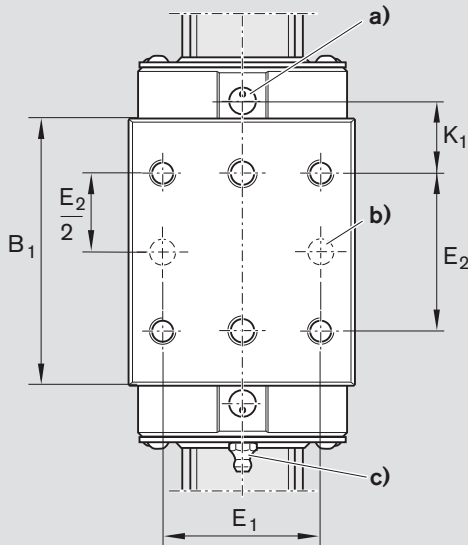
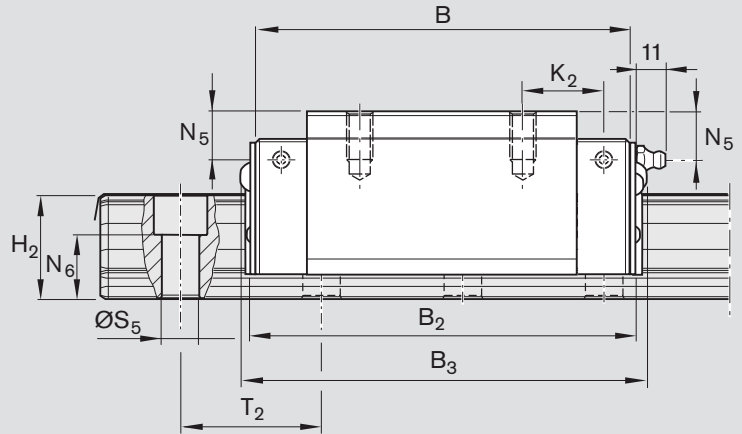
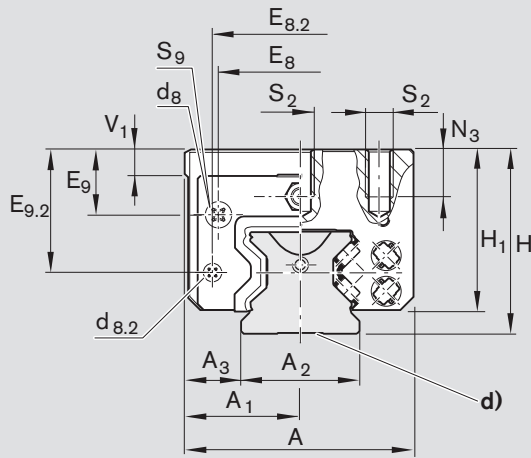

- a) For O-ring
 Size 25: dia. 5 · 1.5 (mm)
 Sizes 35 to 55: dia. 7 · 1.5 (mm)
 Open lube bore as required. Send for instructions.
 For new constructions, use runner blocks for lubrication from above.
- b) Recommended location for pin holes
 (see "Mounting Instructions", section on "Locating Pins").
 Due to manufacturing reasons, there may be rough-drilled holes at the recommended positions. These can be bored open.
- c) Lube nipple, thread M6 – 8 deep:
 can be fitted on all sides (end face only on size 25).
 Other lube fittings will have different dimensions.
 For more details on lube fittings, see the "Accessories" section.
- d) Due to manufacturing reasons, guide rails in accuracy class H may not have a slot on the base.

Size	Dimensions (mm)															
	A	A ₁	A ₂	A ₃	B	B ₁	B ₂	B ₃	d ₈	d _{8.2}	E ₁	E ₂	E ₈	E _{8.2}	E ₉	E _{9.2}
25	48	24	23	12.5	91.0	63.5	93.0	97	6	5	35	35	33.4	40.22	12.40	25.40
35	70	35	34	18.0	114.0	79.6	116.0	121	6	5	50	50	50.3	56.60	20.10	36.10
45	86	43	45	20.5	140.0	101.5	144.0	150	8	6	60	60	62.9	69.55	26.75	46.50
55	100	50	53	23.5	166.5	123.1	170.5	177	10	6	75	75	74.2	81.60	28.95	50.75

Size	Dimensions (mm)															Weight kg
	H	H ₁	H ₂ ¹⁾	H ₂ ²⁾	K ₁	K ₂	N ₃	N ₅	N ₆ ^{±0.5}	S ₂	S ₅	S ₉ ³⁾	T ₂ ⁴⁾	V ₁		
25	40	34	23.60	23.40	19.10	-	9	9.5	14.3	M6	7	M3-5deep	30.0	7.5	0.6	
35	55	48	31.10	30.80	21.55	23.40	13	14.0	19.4	M8	9	M3-5deep	40.0	8.0	1.5	
45	70	61	39.10	38.80	27.45	30.35	18	18.0	22.4	M10	14	M4-7deep	52.5	10.0	3.1	
55	80	68	47.85	47.55	31.75	34.95	19	19.0	28.7	M12	16	M5-8deep	60.0	12.0	4.6	

- 1) Dimension H₂ with cover strip
- 2) Dimension H₂ without cover strip
- 3) Thread for attachments
- 4) Dimension T₂ = hole spacing in the guide rail