

Overview of formats

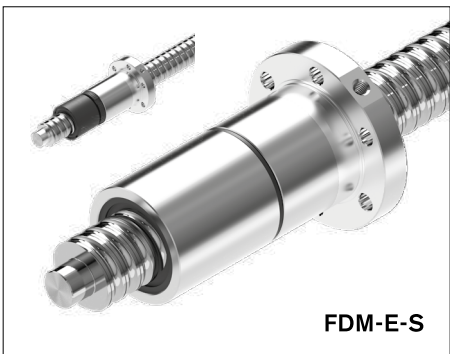
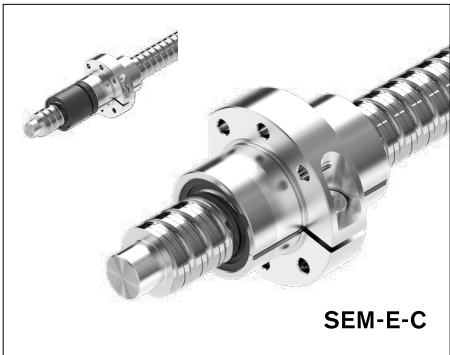
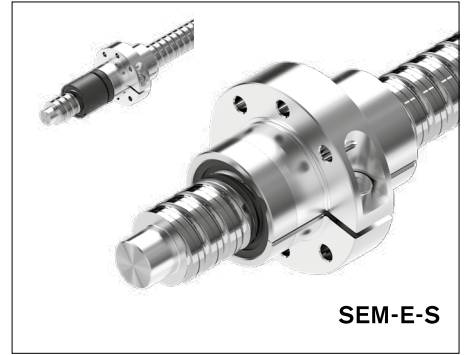
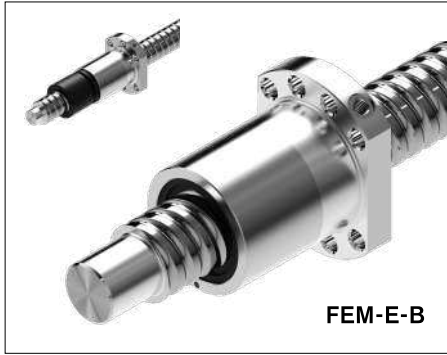
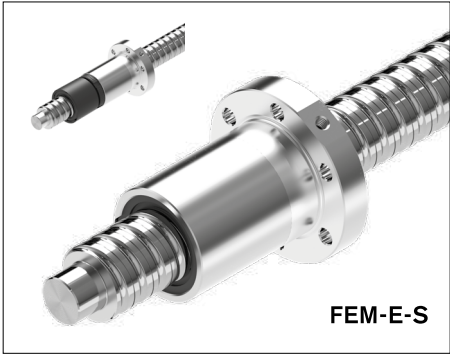

Ball screw assemblies BASA

Single nut with flange FEM-E-B

Mounting dimensions similar to
DIN 69051, Part 5
Flange type B

With seals
With left-hand version in some cases
Preload class: C0, C00, C1, C2, C3
Tolerance grade: T3²⁾, T5, T7, T9

Note: The front lube unit is only available
for the right-hand version.

▲ When setting up applications, do not
allow components to collide with the
front lube unit.

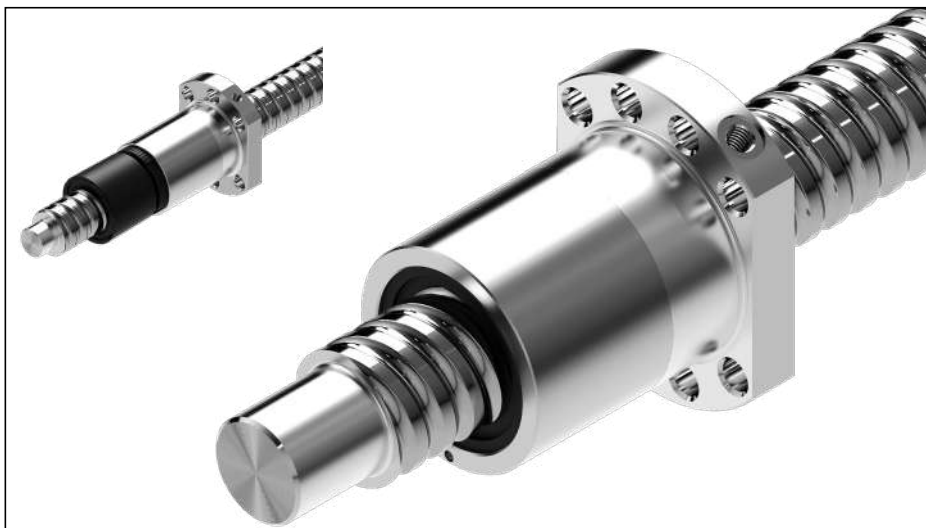

Ordering data:

BASA	20 x 5R x 3	FEM-E-B - 4	00	1	2	T7	R	82Z120	41Z120	1250	0	1
------	-------------	-------------	----	---	---	----	---	--------	--------	------	---	---

d_0 = nominal diameter
 P = lead (R = right-hand, L = left-hand)
 D_w = ball diameter
 i = number of ball track turns

Category	Size $d_0 \times P \times D_w - i$	Part number	Load ratings ³⁾		Linear speed ¹⁾ v_{max} (m/min)
			dyn. C (N)	stat. C ₀ (N)	
A	16 x 5R x 3 - 4	R1502 010 63	14,800	16,100	30
A	16 x 10R x 3 - 3	R1502 040 83	11,500	12,300	60
A	16 x 16R x 3 - 3	R1502 060 63	11,200	12,000	96
A	20 x 5R x 3 - 4	R1502 110 83	17,200	21,500	30
A	20 x 10R x 3 - 4	R1502 140 63	16,900	21,300	60
A	20 x 20R x 3.5 - 3	R1502 170 63	16,000	18,800	120
A	25 x 5R x 3 - 4	R1502 210 83	19,100	27,200	30
A	25 x 10R x 3 - 4	R1502 240 83	18,800	27,000	60
A	25 x 25R x 3.5 - 3	R1502 280 63	17,600	23,300	150
A	32 x 5R x 3.5 - 4	R1502 310 83	25,900	40,000	23
A	32 x 10R x 3.969 - 5	R1502 340 84	38,000	58,300	47
A	32 x 20R x 3.969 - 3	R1502 370 63	23,600	33,700	94
A	32 x 32R x 3.969 - 3	R1502 390 63	23,400	34,000	150
A	40 x 5R x 3.5 - 5	R1502 410 84	34,900	64,100	19
A	40 x 10R x 6 - 4	R1502 440 83	60,000	86,400	38
B	40 x 10R x 6 - 6	R1502 440 84	86,500	132,200	38
C	40 x 12R x 6 - 4	R1502 450 63	59,900	86,200	45
C	40 x 16R x 6 - 4	R1502 460 63	59,600	85,900	60
A	40 x 20R x 6 - 3	R1502 470 83	45,500	62,800	75
B	40 x 25R x 6 - 4	R1502 480 83	56,900	85,800	93
B	40 x 30R x 6 - 4	R1502 4A0 83	56,300	85,100	112
A	40 x 40R x 6 - 3	R1502 490 63	44,400	62,300	150
B	50 x 5R x 3.5 - 5	R1502 510 84	38,400	81,300	15
B	50 x 10R x 6 - 6	R1502 540 84	95,600	166,500	30
C	50 x 12R x 6 - 6	R1502 550 64	95,500	166,400	36
C	50 x 16R x 6 - 6	R1502 560 64	95,300	166,000	48
B	50 x 20R x 6.5 - 5	R1502 570 84	90,800	149,700	60
B	50 x 25R x 6.5 - 4	R1502 580 84	71 800	149 700	75
B	50 x 30R x 6.5 - 4	R1502 5A0 83	71,300	118,800	90
B	50 x 40R x 6.5 - 3	R1502 590 63	55,800	85,900	120
B	63 x 10R x 6 - 6	R1502 640 84	106,600	214,300	24
B	63 x 20R x 6.5 - 5	R1502 670 84	100,700	190,300	48
B	63 x 40R x 6.5 - 3	R1502 690 63	64,100	114,100	95
C	80 x 10R x 6.5 - 6	R1502 740 84	130,100	291,700	19
C	80 x 20R x 12.7 - 6	R1502 770 94	315,200	534,200	30
C	80 x 40R x 12.7 - 4	R1502 790 94	216,600	367,600	60
Versions with left-hand lead					
B	16 x 5L x 3 - 4	R1552 010 63	14,800	16,100	30
B	20 x 5L x 3 - 4	R1552 110 83	17,200	21,500	30
B	25 x 5L x 3 - 4	R1552 210 83	19,100	27,200	30
B	32 x 5L x 3.5 - 4	R1552 310 63	25,900	40,000	23
B	40 x 5L x 3.5 - 5	R1552 410 64	34,900	64,100	19
B	40 x 10L x 6 - 4	R1552 440 63	60,000	86,400	38

- See "Characteristic speed $d_0 \cdot n$ " on page 133 and "Critical speed n_{cr} " on page 174
- Tolerance grade T3 for sizes shown in table page 12
- The load ratings are valid for tolerance grade T3 and T5 only.
For other tolerance grades, please take into account the correction factor f_{ac} on page 133.
- Lube port machining: flat surface $L_3 \leq 15$ mm, countersink $L_3 > 15$ mm;
- With left-hand lead the lube port position mirrors its position with right-hand lead!
- The axial lube port S_x is always located on the pitch circle D_6 of the nut unit.

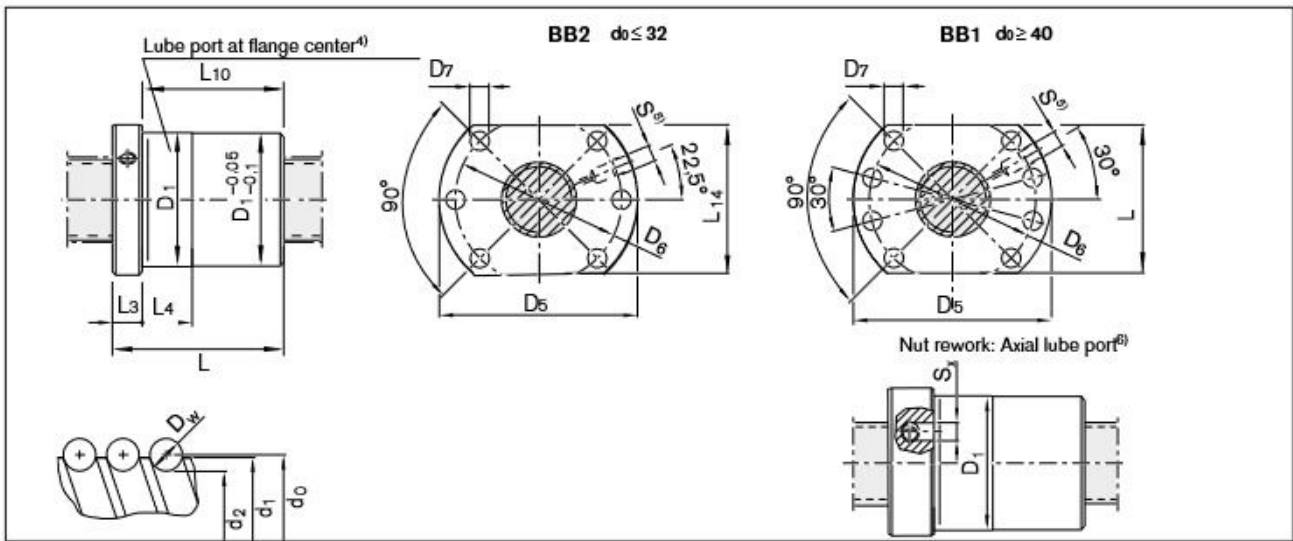

Size	(mm)															Mass m (kg)
	d1	d2	D1 g6	D5	Hole pattern	D6	D7	L	L3	L4	L10	L14	S4	S6		
16 x 5R x 3 - 4	15	12.9	28	48	BB2	38	5.5	38	12	10	26	40.0	M6	4	0.19	
16 x 10R x 3 - 3	15	12.9	28	48	BB2	38	5.5	45	12	16	33	40.0	M6	4	0.21	
16 x 16R x 3 - 3	15	12.9	28	48	BB2	38	5.5	61	12	20	49	40.0	M6	4	0.26	
20 x 5R x 3 - 4	19	16.9	36	58	BB2	47	6.6	40	12	10	28	44.0	M6	4	0.31	
20 x 10R x 3 - 4	19	16.9	36	58	BB2	47	6.6	60	12	16	48	44.0	M6	4	0.40	
20 x 20R x 3.5 - 3	19	16.7	36	58	BB2	47	6.6	77	12	25	65	44.0	M6	4	0.49	
25 x 5R x 3 - 4	24	21.9	40	62	BB2	51	6.6	45	12	10	33	48.0	M6	4	0.36	
25 x 10R x 3 - 4	24	21.9	40	62	BB2	51	6.6	64	12	16	52	48.0	M6	4	0.47	
25 x 25R x 3.5 - 3	24	21.4	40	62	BB2	51	6.6	95	12	30	83	48.0	M6	4	0.63	
32 x 5R x 3.5 - 4	31	28.4	50	80	BB2	65	9.0	48	13	10	35	62.0	M6	4	0.62	
32 x 10R x 3.969 - 5	31	27.9	50	80	BB2	65	9.0	77	13	16	64	62.0	M6	4	0.84	
32 x 20R x 3.969 - 3	31	27.9	50	80	BB2	65	9.0	84	13	25	71	62.0	M6	4	0.90	
32 x 32R x 3.969 - 3	31	27.9	50	80	BB2	65	9.0	120	13	40	107	62.0	M6	4	1.21	
40 x 5R x 3.5 - 5	39	36.4	63	93	BB1	78	9.0	54	15	10	39	70.0	M8x1	5	1.03	
40 x 10R x 6 - 4	38	33.8	63	93	BB1	78	9.0	70	15	16	55	70.0	M8x1	5	1.19	
40 x 10R x 6 - 6	38	33.8	63	93	BB1	78	9.0	90	15	16	75	70.0	M8x1	5	1.49	
40 x 12R x 6 - 4	38	33.8	63	93	BB1	78	9.0	75	15	25	60	70.0	M8x1	5	1.27	
40 x 16R x 6 - 4	38	33.8	63	93	BB1	78	9.0	90	15	25	75	70.0	M8x1	5	1.51	
40 x 20R x 6 - 3	38	33.8	63	93	BB1	78	9.0	88	15	25	73	70.0	M8x1	5	1.44	
40 x 25R x 6 - 4	38	33.8	63	93	BB1	78	9.0	127	15	30	112	70.0	M8x1	5	1.91	
40 x 30R x 6 - 4	38	33.8	63	93	BB1	78	9.0	145	15	35	130	70.0	M8x1	5	2.21	
40 x 40R x 6 - 4	38	33.8	63	93	BB1	78	9.0	142	15	45	127	70.0	M8x1	5	2.16	
50 x 5R x 3.5 - 5	49	46.4	75	110	BB1	93	11.0	54	15	10	39	85.0	M8x1	5	1.39	
50 x 10R x 6 - 6	48	43.8	75	110	BB1	93	11.0	90	18	16	72	85.0	M8x1	5	2.14	
50 x 12R x 6 - 6	48	43.8	75	110	BB1	93	11.0	105	18	25	87	85.0	M8x1	5	2.38	
50 x 16R x 6 - 6	48	43.8	75	110	BB1	93	11.0	128	18	25	110	85.0	M8x1	5	2.75	
50 x 20R x 6.5 - 5	48	43.4	75	110	BB1	93	11.0	132	18	25	114	85.0	M8x1	5	2.73	
50 x 25R x 6.5 - 4	48	43.4	75	110	BB1	93	11.0	132	18	25	114	85.0	M8x1	-	2.78	
50 x 30R x 6.5 - 4	48	43.4	75	110	BB1	93	11.0	151	18	35	139	85.0	M8x1	5	3.12	
50 x 40R x 6.5 - 3	48	43.4	75	110	BB1	93	11.0	149	18	45	131	85.0	M8x1	5	3.04	
63 x 10R x 6 - 6	61	56.8	95	135	BB1	108	11.0	90	22	16	68	95.0	M8x1	5	2.56	
63 x 20R x 6.5 - 5	61	56.4	95	135	BB1	115	13.5	132	22	25	110	100.0	M8x1	5	4.51	
63 x 40R x 6.5 - 3	61	56.4	95	135	BB1	115	13.5	149	22	45	127	100.0	M8x1	5	5.04	
80 x 10R x 6.5 - 6	78	73.3	105	145	BB1	125	13.5	95	22	16	73	110.0	M8x1	5	3.40	
80 x 20R x 12.7 - 6	76	67.0	125	165	BB1	145	13.5	170	25	25	145	130.0	M8x1	5	10.20	
80 x 40R x 12.7 - 4	76	67.0	125	165	BB1	145	13.5	206	25	25	181	130.0	M8x1	5	11.60	
Versions with left-hand lead																
16 x 5L x 3 - 4	15	12.9	28	48	BB2	38	5.5	38	12	10	26	40.0	M6	4	0.19	
20 x 5L x 3 - 4	19	16.9	36	58	BB2	47	6.6	40	12	10	28	44.0	M6	4	0.31	
25 x 5L x 3 - 4	24	21.9	40	62	BB2	51	6.6	45	12	10	33	48.0	M6	4	0.36	
32 x 5L x 3.5 - 4	31	28.4	50	80	BB2	65	9.0	48	13	10	35	62.0	M6	4	0.62	
40 x 5L x 3.5 - 5	39	36.4	63	93	BB1	78	9.0	54	15	10	39	70.0	M8x1	5	1.03	
40 x 10L x 6 - 4	38	33.8	63	93	BB1	78	9.0	70	15	16	55	70.0	M8x1	5	1.19	