

## Model RU (Integrated Inner/Outer Ring Type)

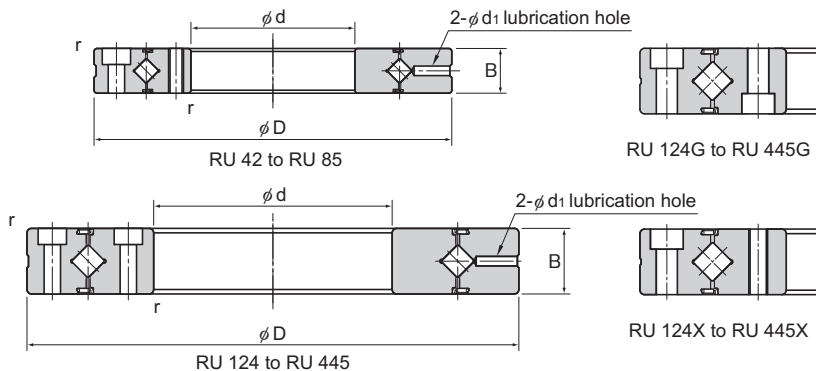

Shaft diameter	Model No.	Main dimensions						Shoulder height		Basic load rating (radial)		Mass
		Inner diameter d	Outer diameter D	Roller pitch circle diameter dp	Width B	Lubrication hole d <sub>1</sub>	r <sub>min</sub>	ds (max)	Dh (min)	C	C <sub>0</sub>	
20	RU 42	20	70	41.5	12	3.1	0.6	36	47	7.35	8.35	0.29
35	RU 66	35	95	66	15	3.1	0.6	59	74	17.5	22.3	0.62
55	RU 85	55	120	85	15	3.1	0.6	77	93	20.3	29.5	1
80	RU 124 (G)	80	165	124	22	3.1	1	114	134	33.1	50.9	2.6
	RU 124X											
90	RU 148 (G)	90	210	147.5	25	3.1	1.5	133	162	49.1	76.8	4.9
	RU 148X											
115	RU 178 (G)	115	240	178	28	3.1	1.5	161	195	80.3	135	6.8
	RU 178X											
160	RU 228 (G)	160	295	227.5	35	6	2	208	246	104	173	11.4
	RU 228X											
210	RU 297 (G)	210	380	297.3	40	6	2.5	272	320	156	281	21.3
	RU 297X											
350	RU 445 (G)	350	540	445.4	45	6	2.5	417	473	222	473	35.4
	RU 445X											

Note) Optional grease nipple available for model RU. (See figure below.)

To indicate that you want grease nipples, add "-N" to the end of the model number.

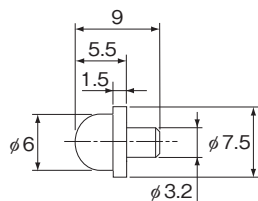

NP3.2×3.5

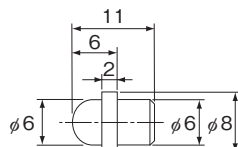

NP6×5

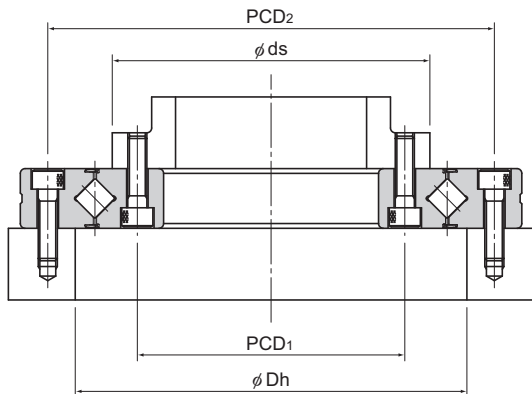

Model RU

Model RU...U



Model RU...UU

Model RU...UT

Unit: mm

Mounting Hole Related				
Inner ring			Outer ring	
PCD <sub>1</sub>	Mounting hole		PCD <sub>2</sub>	Mounting hole
28	6-M3 through		57	6- $\phi$ 3.4 drilled through, $\phi$ 6.5 counter bore depth 3.3
45	8-M4 through		83	8- $\phi$ 4.5 drilled through, $\phi$ 8 counter bore depth 4.4
65	8-M5 through		105	8- $\phi$ 5.5 drilled through, $\phi$ 9.5 counter bore depth 5.4
97	10- $\phi$ 5.5 drilled through, $\phi$ 9.5 counter bore depth 5.4 10-M5 through		148	10- $\phi$ 5.5 drilled through, $\phi$ 9.5 counter bore depth 5.4
112	12- $\phi$ 9 drilled through, $\phi$ 14 counter bore depth 8.6 12-M8 through		187	12- $\phi$ 9 drilled through, $\phi$ 14 counter bore depth 8.6
139	12- $\phi$ 9 drilled through, $\phi$ 14 counter bore depth 8.6 12-M8 through		217	12- $\phi$ 9 drilled through, $\phi$ 14 counter bore depth 8.6
184	12- $\phi$ 11 drilled through, $\phi$ 17.5 counter bore depth 10.8 12-M10 through		270	12- $\phi$ 11 drilled through, $\phi$ 17.5 counter bore depth 10.8
240	16- $\phi$ 14 drilled through, $\phi$ 20 counter bore depth 13 16-M12 through		350	16- $\phi$ 14 drilled through, $\phi$ 20 counter bore depth 13
385	24- $\phi$ 14 drilled through, $\phi$ 20 counter bore depth 13 24-M12 through		505	24- $\phi$ 14 drilled through, $\phi$ 20 counter bore depth 13

## Model number coding

**RU124 UU CC0 P2 B G -N**

Model No.

Accuracy symbol (\*2)

Radial clearance symbol (\*1)

Sub-part Accuracy symbol

No Symbol : Rotational Accuracy of the Inner Ring

R : Rotational Accuracy of the Outer Ring

B : Rotational Accuracy of the Inner/Outer Rings

Grease nipple symbol

No Symbol : No grease nipples included

-N : Grease nipples attached (2)

(For the nipple's shape,

see the figure on the left.)

RU42 to RU178: NP3.2 × 3.5

RU228 to RU445: NP6 × 5

Seal symbol

No Symbol : Without seal

UU : Seal attached on both ends

U : Seal attached on either end

(counterbore side of the outer ring)

UT : Seal attached on either end

(opposite to the counterbore

side of the outer ring)

Mounting Hole Symbol

[Applicable Models : RU124 to RU445(RU42 to RU85 do not apply)]

No Symbol : The counterbore holes of the inner and outer rings

face the same direction

G : The counterbore holes of the inner and outer rings

face opposite direction

X : Inner ring tapped hole (through hole)

(\*1) See A18-18. (\*2) See A18-12.